

## Flashback Arrestors

### FEATURES & BENEFITS:

- Built-in check valve prevents the reverse flow of gas
- Requires no manual reset
- Easy to install - attaches to standard "B" fittings
- High quality brass construction, case is rugged and corrosion resistant
- Sintered stainless steel filter stops flashback fire
- UL Listed



### Frequently asked questions about flashback arrestors:

#### What is a flashback?

A flashback is an ignition of mixed gases in an oxy-fuel cutting and welding system.

#### Are flashback arrestors and check valves the same?

No. A check valve stops the reverse flow of gas; a flashback arrestor is designed to help stop the advancement of a flashback fire. Smith's flashback arrestor with built-in check valve does both.

#### Why do I need a flashback arrestor?

Mixed gas explosions and flashback fires can result in damage to equipment and/or severe personal injury or death. Smith flashback arrestors with built-in check valves help prevent accidents caused by the reverse flow of gases and flashback fires.

#### What is the minimum pressure required to allow gas to flow through the flashback arrestors?

The built-in check valve requires a minimum of 2 psi to open allowing gas to flow through.

**NOTE:** Smith Equipment cannot accept return of check valves or flashback arrestors as return shipping may compromise their performance capabilities.

H753

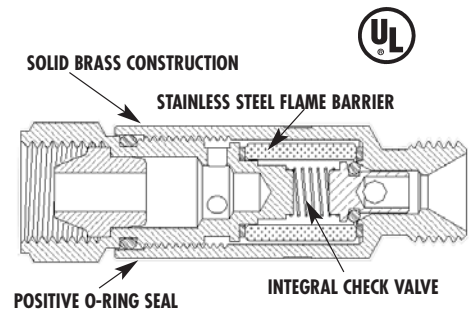

**May Be Used With:** Acetylene, propane, propylene, hydrogen and natural gas.

### REGULATOR MOUNT For use with CGA "B" male fitting.

Stock No.	Gas
H753	Oxygen & Fuel Gas Pair

### TORCH MOUNT (HIGH FLOW)

Stock No.	Gas
H743	Oxygen & Fuel Gas Pair

### PRESSURE SETTINGS

**CAUTION:** Flashback arrestors will contribute to significant pressure drop in a system, causing reduced flow. Pressure increase may be required to maintain equivalent flow rates after installing flashback arrestors in an oxy-fuel system.

**CAUTION:** DO NOT exceed 15 PSIG with acetylene gas.

**NOTE:** Flashback Arrestors should be tested and inspected on a regular basis.

### Oxygen Flow Capacity

Oxygen Flash Arrestors

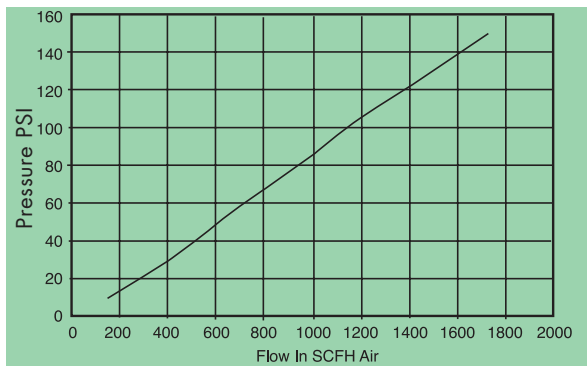

### Fuel Flow Capacity

Fuel Flash Arrestors

